

# Programming The Energy Power™ Bar To Your TV Remote

The Energy Power™ Bar soundbar has four control buttons under the status indicator light on its front panel. From the top button down, they are SOURCE, MUTE, VOLUME UP, and VOLUME DOWN. These buttons can easily be programmed to your TV, Satellite or Cable box remote control so that you can use that remote to control these functions.

**NOTE:** The soundbar is pre-programmed to have the four control buttons automatically operate with many Samsung TV remote controls without the need for programming.

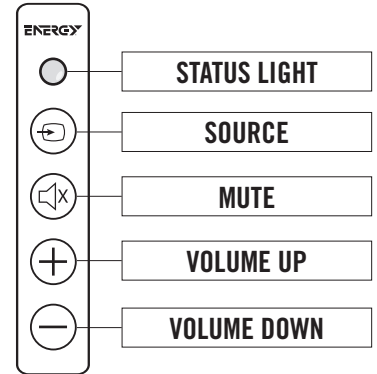

**IMPORTANT NOTE:** There is not a power on/off button on the front of the soundbar (there is a Main Power switch on the soundbar's rear panel). You do not need to turn off the soundbar (or subwoofer) when finished watching TV. When finished, turn off your TV (or Satellite or Cable box if the soundbar is connected to that). The soundbar (and the subwoofer) will automatically go into a Standby or "sleep" mode if they do not receive an audio signal from your TV, Satellite or Cable Box for approximately 10 minutes. Standby mode is indicated by a solid red status light on the soundbar front and on the subwoofer rear panel. When your TV, Satellite or Cable box is turned back on and a signal is again received, the soundbar (and subwoofer) will automatically come out of Standby mode and turn on.

## Easy, Three-Step Remote Programming

The following 3 steps should be used to program each function of your TV or cable box remote control buttons (SOURCE, MUTE, VOLUME UP, and VOLUME DOWN). **IF THE SOUNDBAR IS IN STANDBY MODE** (solid RED status light), push the <SOURCE> button on the soundbar until the status light is solid GREEN.

**STEP ONE (Place the unit in learning mode):** With the status light showing solid GREEN, press and hold the <SOURCE> and <MUTE> buttons on the front of the soundbar at the same time (approximately 3 seconds) until the status light flashes ORANGE.

**STEP TWO (Select the function to learn):** Press the <MUTE> button once on the soundbar (the status light changes to solid ORANGE). (Substitute the SOURCE, VOLUME UP & VOLUME DOWN in place of <MUTE> when programming the other buttons during this step)

**STEP THREE (Learn the function):** Hold your remote control within one foot and pointed at the front of the soundbar. Slowly press the <MUTE> button on your remote control four times. On the first three presses, the status indicator light will flicker ORANGE with each press. If the unit has successfully learned the function, on the fourth press of the button, the light will flash GREEN several times and then turn to solid GREEN. (Remember to use the SOURCE, VOLUME UP, and VOLUME DOWN in place of <MUTE> when programming the other buttons during this step)

To program the remaining functions, simply repeat all steps, substituting <MUTE> with the new function and button presses (SOURCE, VOLUME UP, and VOLUME DOWN) on steps TWO and THREE.

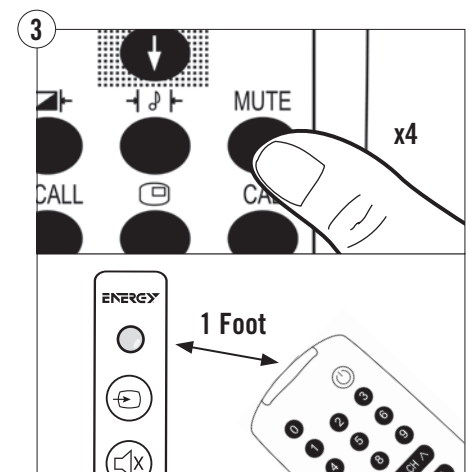
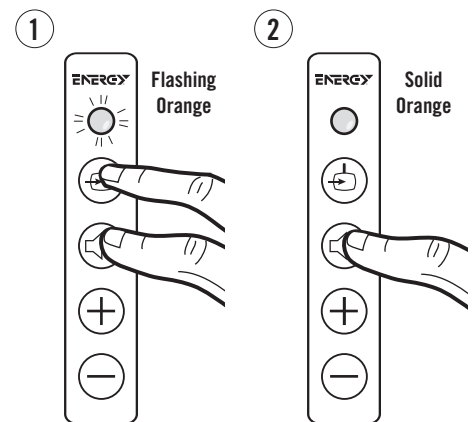

# Connecting The Energy Power™ Bar

## Step 1

Once you have placed the Energy Power™ Bar soundbar where you want it either below or above your TV, connect one end of the supplied optical digital cable to your TV's optical digital audio output jack and connect the other end of the cable into the optical input jack on the rear of the soundbar.

NOTE: REMOVE PROTECTIVE END CAPS ON EACH END OF THE OPTICAL CABLE.

NOTE: THE SOURCE BUTTON ON THE SOUNDBAR SWITCHES INPUTS BACK AND FORTH FROM OPTICAL TO L/R RCA.

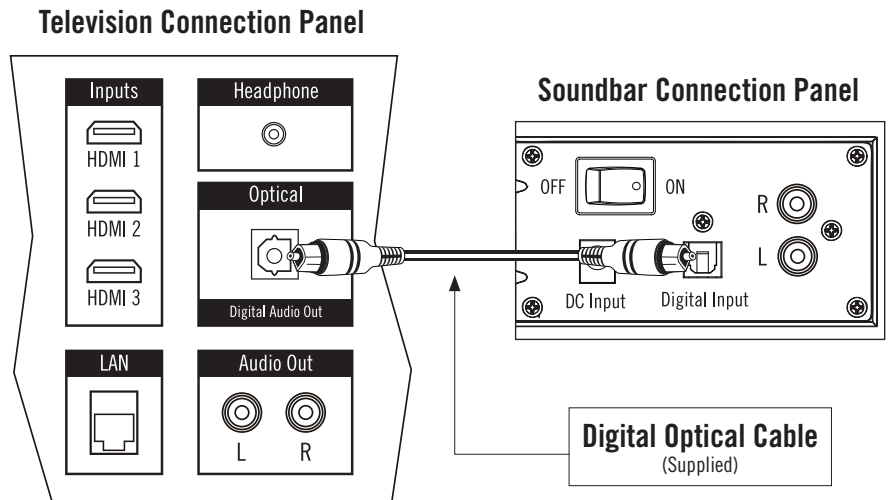

## Step 2

Next, plug the AC power cord into the soundbar power supply, then connect the power supply into the AC Input on the rear of the soundbar. Plug the AC power supply into a "live" electrical outlet and turn the soundbar's Main Power switch on the rear of the soundbar to "On". On the front of the soundbar, make sure the status light is either solid green or orange (press any button once if light is steady red).

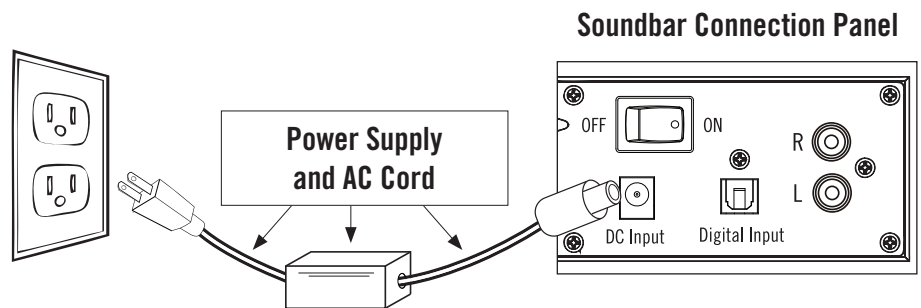

## Step 3

Last, after placing the Energy Power™ Bar subwoofer where you want it in the room, take the subwoofer AC power cord and plug one end into the "AC Input" on the back of the subwoofer and the other end into a nearby "live" power outlet. Turn the subwoofer Main Power switch on the back of the subwoofer to "On". The orange light will turn on until it finds the wireless signal coming from the soundbar. Once it finds that signal (approximately 15 seconds), the solid orange light will change to solid blue, indicating the subwoofer is now connected to the soundbar. Your Energy Power™ Bar system is now ready to operate!

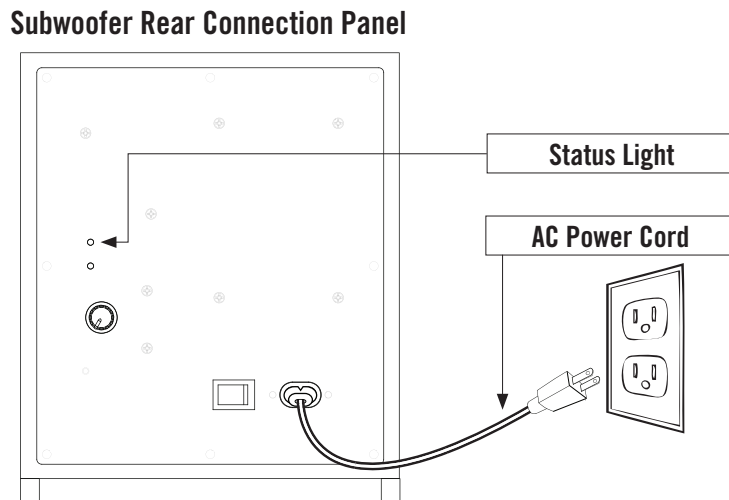

(For more information, refer to the owner's manual)